

Application

- Car wash
- Repair and maintenance
- Body work



Sololift 1.35 Saa

Electro-hydraulic single-ram lift, 3.5 t capacity, superstructure with arms

Description:

Steel cassette:

- Waterproof steel cassette
- Self-carrying

Hydraulic unit:

- Hard-chrome plated cylinder
- Integrated anti-rotation device
- Corrosion-free guiding elements
- Hydraulic unit with immersed motor for fitting in floor
- Ecological hydraulic fluid
- Pneumatic emergency lowering
- Pushbutton control unit

Superstructure:

- Double telescopic arms
- Internal arm locking system
- Low minimum height

Standard colours

- Base plate: Grey RAL 7016
- Arms: Red RAL 3020

Technical data	
Lifting capacity	3,500 kg
Lifting height	1,780 m
Working height	1,875 - 1,925 mm
Cylinder diameter	123 mm
Lifting / lowering time	app. 30 Sec.
Foundation depth	2,400 mm
Pump unit	3.0 kW
Ecological hydraulic fluid	12 l
Voltage	230/400 V - 50 Hz - 16 A

Arm superstructure	
Min. height	95 - 145 mm
Arm length, min. - max.	595 - 1,220 mm

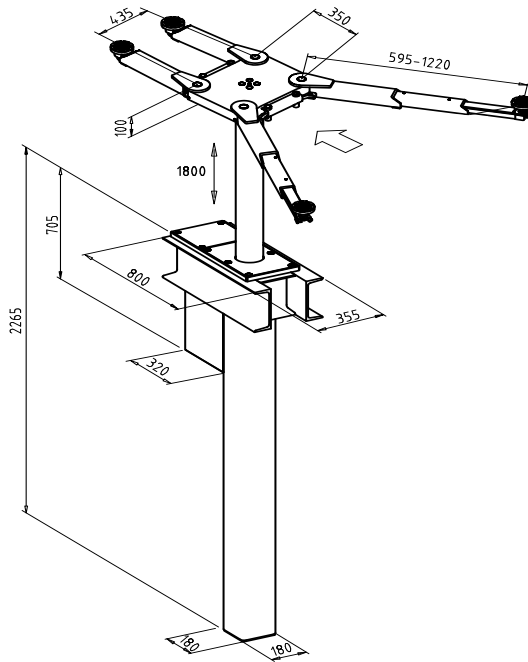

Scan the QR-Code for detailed product information.

Further Information on www.autopstenhoj.com

Versions:

Steel cassette:

- Zinc-coated
- Coated

Installation:

- Superstructure on floor
- Ceiling installation
- Hydraulic pump unit in floor
- Hydraulic pump unit on wall

Optional extras:

- Large program of extra pads

Special colours available on request!